

01 - 2000 S. AG.

2 - Hood

CODE	DESCRIPTION
120313	DOOR MICROSWITCH
150819	CABLE HOLDER PG16 WITH HOLE
160803	GASKET D.5
160837	GASKET FOR TIE ROD BC-FC
160838	SLIDING WASHER TIE ROD FC
160905	SLIDING PLATE F. TIE ROD
170812	GREY DOOR HANDLE
180506	DOOR CATCH BR-BC-FC
190619	DOOR CATCH B-F-R
200923	DOOR GASKET
200924	GASKET
260126	SCREW TE 5X12
260223	M5X12 MSH/HD SCREW SPECIAL S/S
260224	TB-SCREW 6X15 B23-10-11-12
260238	M4 X 10 MUSH/HD SCREW
322315	COVER FOR LF W/BREAK TANK
322422	RIGHT GUIDE
322423	GUIDE
322954	DOOR F LAV LINE
330231	DOOR ROD FOR FC MACHINES
330820	BUSH DOOR SWITCH F2-20-45-5
331764	FIXING PLATE FOR B-F DOOR GASK
341218	HINGE PIN B-F-G
341461	HOOD
342010	PIN FOR TIE ROD DOOR FC
350725	MICRO BRACKET F300-45-55-65
351298	FRONT PANEL
381002	PIN F.DOOR MICRO F2-20-45-55
390157	BACK COVER
390167	BACK PANEL
440201	RUBBER FOOT D.60X10
441107	DOOR HINGE BR-BC-FC LEFT
441108	DOOR HINGE BR-BC-FC RIGHT

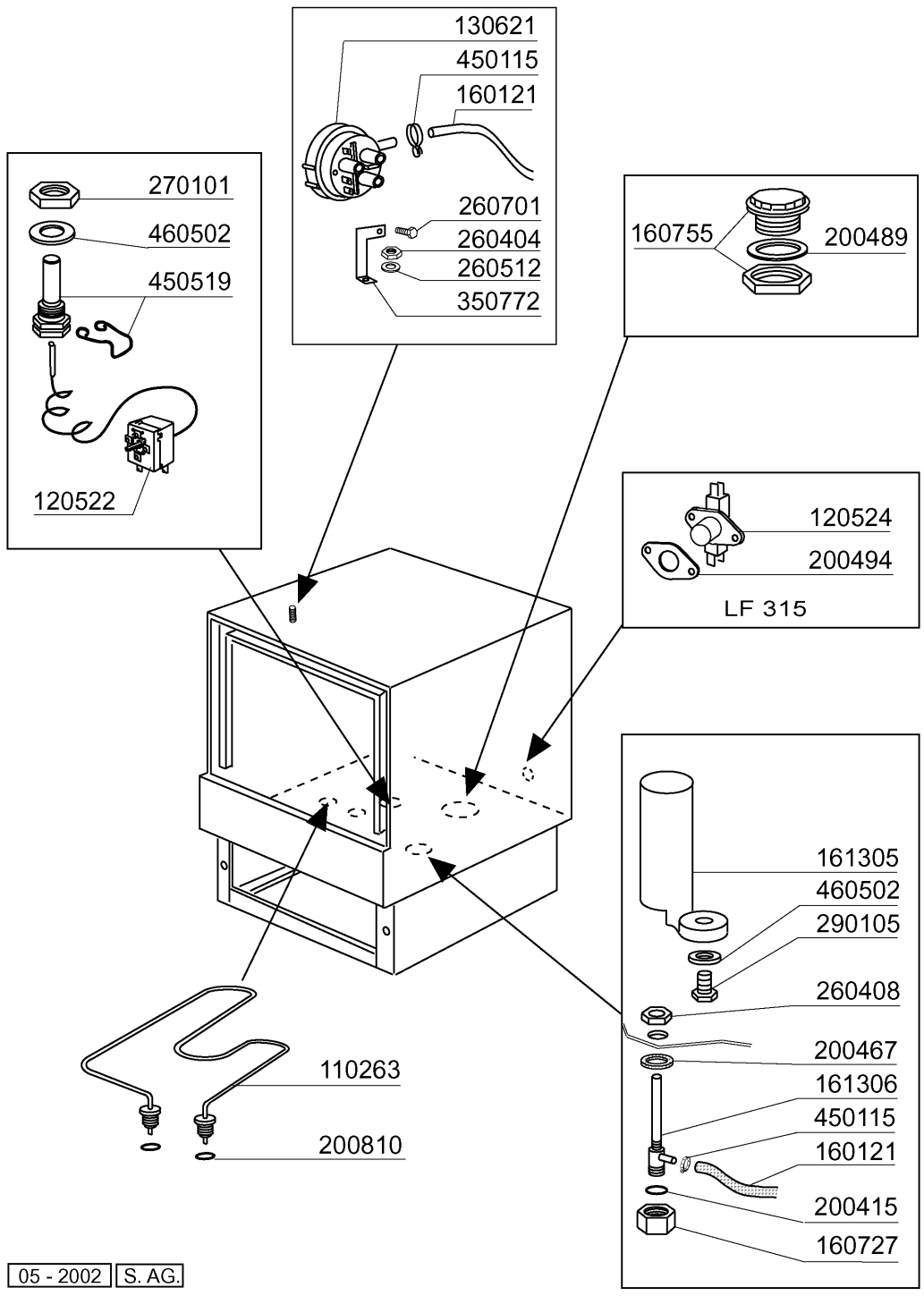

05 - 2002 | S. AG.

3 - Tank

CODE	DESCRIPTION
110263	TANK HEATER 2000W 230V
120522	TANK THERMOSTAT 90Ø
120524	TANKTHERMOSTAT GLASSWASHER
130621	PRESSURE SWITCH FOR BC HR 45/2
160121	HOSE EPDM D. 5 X 9
160727	PLUG 1/2 NTP CAP
160755	PLUG FOR MACHINES WITHOUT SOFT
161305	AIR CHAMBER F45-F80
161306	HOSE FOR AIR CHAMBER F45-80
200415	AIR TRAP GASKET -F2 18,5X10X3
200467	DUTRAL GASKET F. AIR TRAP
200489	GASKET 81X68X3
200494	GASKET FOR TANKTHERMOSTAT BT
200810	O-RING 2,62X9,92X15,6 F.GLASSW
260404	STAINLESS STEEL NUTS D6 UNI 55
260408	S/S NUTS D.12
260512	ST/ST GROWER WASHER D6
260701	SCREW 3,5X9,5
270101	HEXAGON LOCK NUT 1/2"
290105	BRASS-TE-PLUG 1/2"
350772	BRACKET
450115	ELASTIC CLAMP D.8,3/7,8
450519	TANK THERMOSTAT SHIELD C-F
460502	GASKET 30X21X2

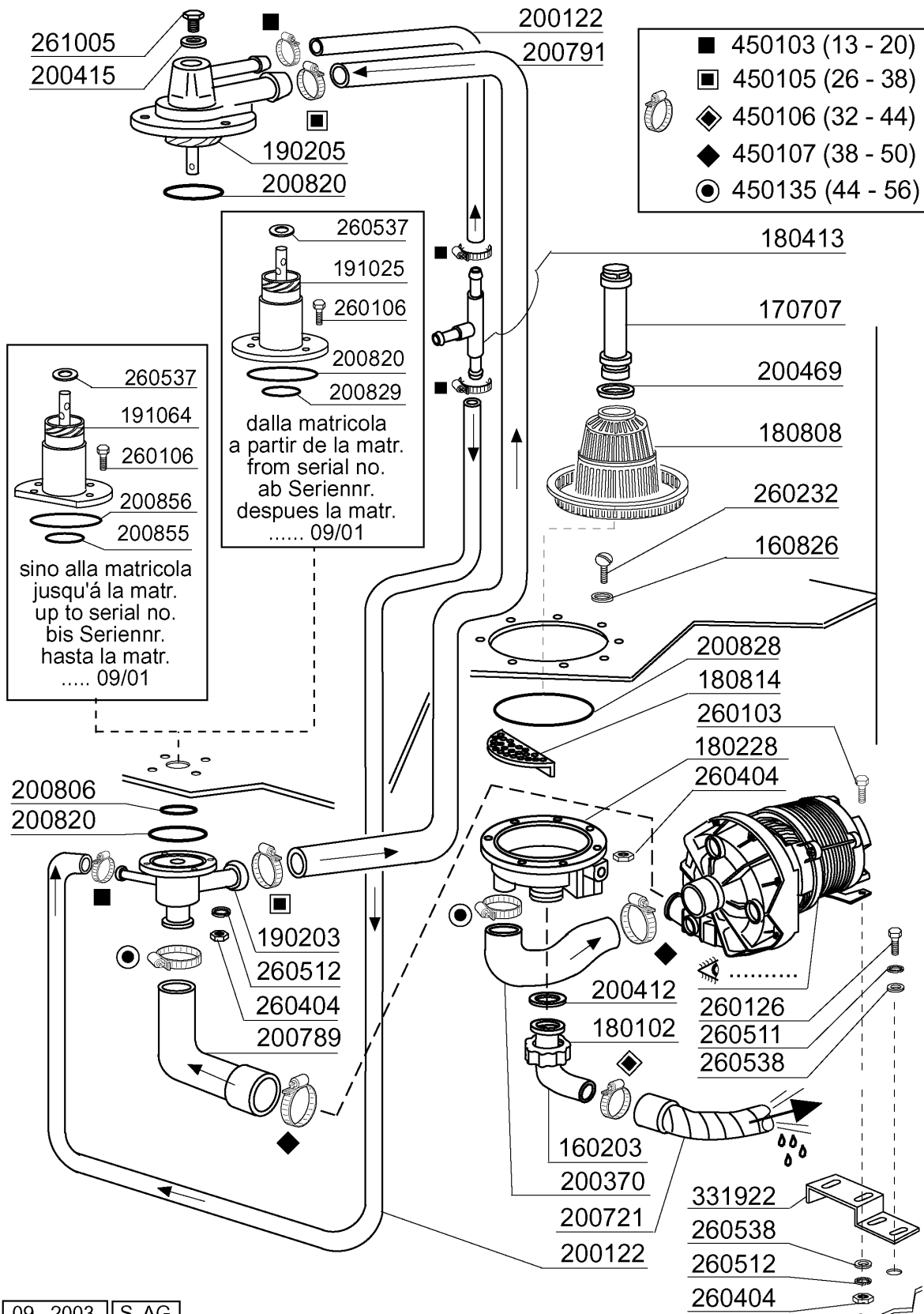

09 - 2003 | S. AG.

4 - Wash

CODE	DESCRIPTION
160203	ELBOW 1"1/2 N-S-F-C /DRAIN
160826	GASKET 14X6,2X2 B41-F2
170707	OVERFLOW PIPE H140-F2-45-55-R
180102	DRAIN PIPE NUT 1"1/2 F45-55
180228	TANK SUCTION BASIN WITHOU.PRES
180413	TEE NIPPLE D.11,5 - RINSE ASSE
180808	STRAINER F2-45-55-80
180814	PROTECT.FILTER OF INLET PUMPE
190203	LOWER TEE WASH-RINSE F2-45-55-
190205	UPP.TEE WASH/RIN ARM F2-45-55-
191025	LOWER WASH ARM SUPP.B-F
191064	LOWER WASH ARM SUPPORT FOR BC-
200122	HOSE 11X19
200370	PUMP INLET HOSE B41-F20-55
200412	GASKET DRAIN 11/2" 45X33X3
200415	AIR TRAP GASKET -F2 18,5X10X3
200469	STAND PIPE O RING 45X35,5X7
200721	DRAIN HOSE 28X35 2MT.
200789	OUTLET HOSE FC
200791	UPPER/LOWER WASH HOSE FC53
200806	O-RING 2,62X13,10X18,34
200820	O-RING151 46,99X5,33X57,6
200828	O-RING 183,75X190,81X3,53
200829	O-RING 81,92X92,58X5,33
200855	GASKET LOWER WASH ARM SUPPORT
200856	O-RING 82,22X87,46X2,62
260103	SCREW TE 6X12
260106	SCREW TE 6X25
260126	SCREW TE 5X12
260232	STAINL.ST TB SCREW 6X25 B15-6-
260404	STAINLESS STEEL NUTS D6 UNI 55
260511	GROWER WASHER D.5
260512	ST/ST GROWER WASHER D6
260537	STAINL.STEEL FLAT WASHER D13X2
260538	WASHER 18X6X1,5 ST/ST
261005	SCREW F. TEE UP.WASH F2-B41
331922	BRACKET F. PUMP "F"
450103	CLAMP FE ZN. 13-20 H=9
450105	CLAMP FE ZN. 26-38 H=12,2
450106	CLAMP FE ZN 32-44 H=12,2
450107	CLAMP FE ZN 38-50 H=12,2
450135	CLAMP FE ZN. 44-56 H=12,2

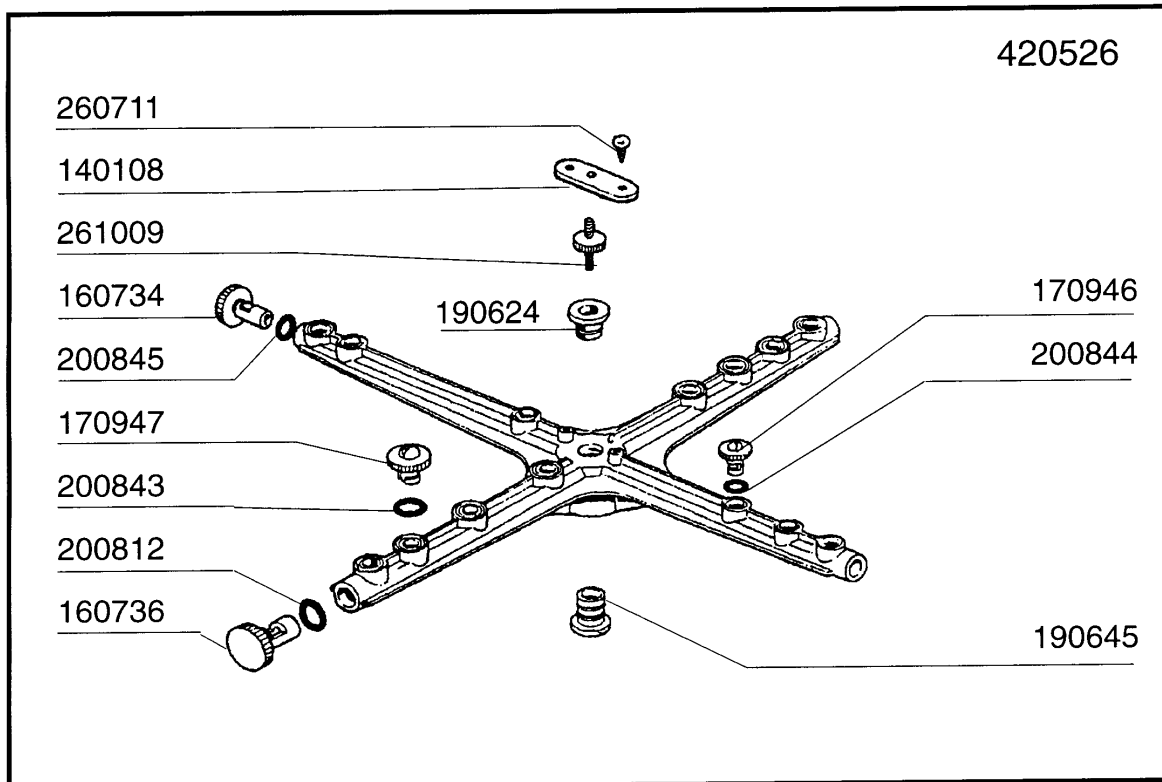
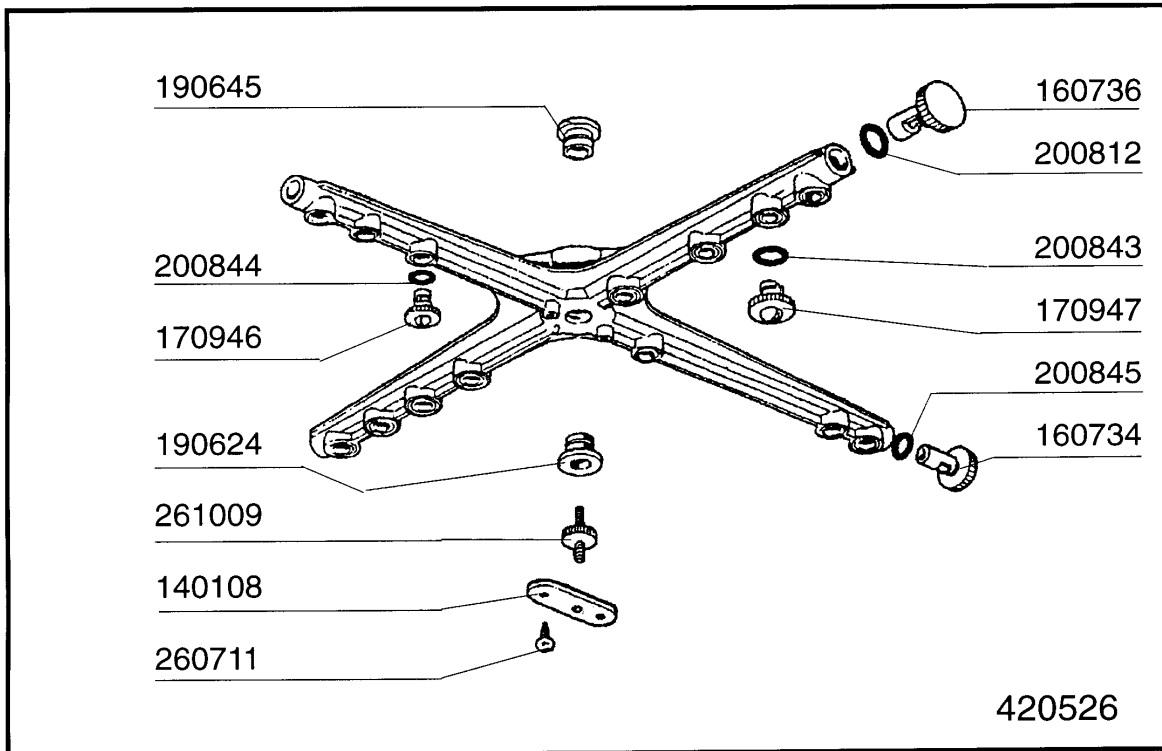

5 - Wash arm

CODE	DESCRIPTION
140108	PLATE FOR WASH ARM
160734	END PLUGS RINSE ARM
160736	WASH ARM PLUG F45
170946	RINSE JET/RINSE ARM B-F
170947	WASH JET/WASH ARM F45-80
190624	BUSH FOR PLASTIC ARM F45
190645	LOWER BUSH FOR WASH ARM F
200812	O-RING 1,78X17,17X20,73
200843	O RING 2X13X17
200844	O RING 2X9,5X13,5
200845	O RING 109 2,62X9,13X14,37
260711	SCREW 4,2X13 A2 DIN7972
261009	RETAIN.SCREW FOR WASH-RINSE AR
420526	PLASTIC WASH-RINSE ARM (F45)

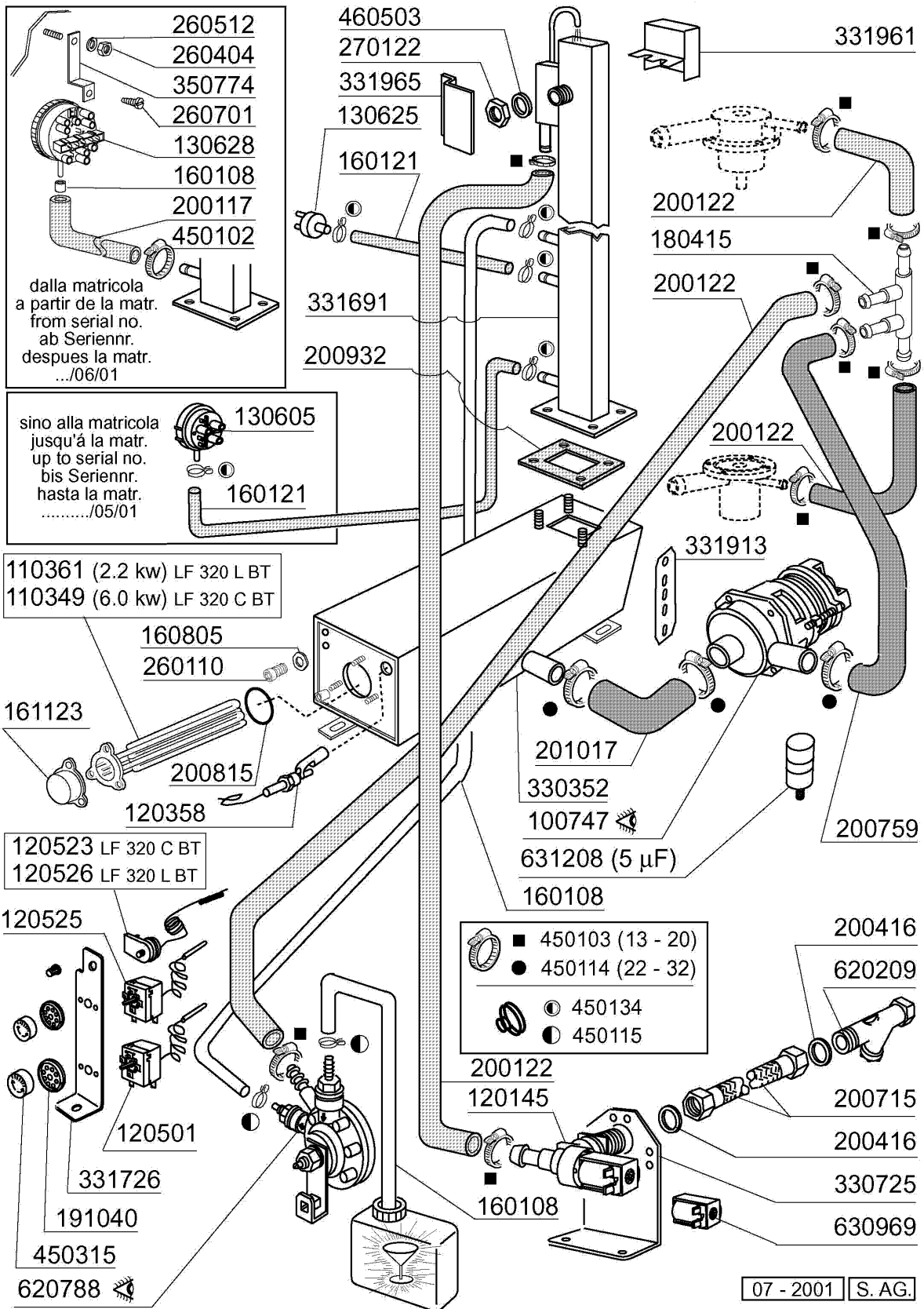

6 - Rinse

CODE	DESCRIPTION
100747	PUMP KW 0,073 220/240-50 4208
110349	HEAT.ELEMENT 6000W 230/400V
110361	HEAT. ELEMENT 2200W 230V
120145	SOLENOID VALVE 12 LT 1 WAY
120358	FLOATING MAGN.SWITCH
120501	THERMOSTAT 30/90°C
120523	SAFETY THERMOSTAT 110°
120525	BOOSTER THERMOSTAT 2 TEMPERAT.
120526	SAFETY THERMOSTAT 2POLES
130605	PRESSURE SWITCH 50-30 1 LEVEL
130625	PRESSURE SWITCH
130628	PRESSURE SWITCH
160108	INJECT.INLET HOSE D.8X5
160121	HOSE EPDM D. 5 X 9
160805	GASKET D.8
161123	HEAT.ELEMENT COVER H42 SNL
180415	TEE NIPPLE DOUBLE "T"
191040	FRAME F.THERMOSTAT KNOB
200117	RUBBER HOSE 7X16
200122	HOSE 11X19
200416	GASKET D. 3/4"
200715	HOSE WATER INLET 2M STAINL.ST
200759	DELIVERY HOSE FOR ECORINSE AC-
200815	O-RING F. HEAT.ELEM.
200932	BOILER GASKET
201017	RINSE PUMP INLET HOSE LF/FC BT
260110	SCREW TE 8X10
260404	STAINLESS STEEL NUTS D6 UNI 55
260512	ST/ST GROWER WASHER D6
260701	SCREW 3,5X9,5
270122	NUTS D.3/4" FOR BREAK TANK
330352	BOILER FOR BREAK TANK
330725	STANDARD BRACKET F.SOLEN.VALV
331691	BREAK TANK FC54-LF
331726	BRACKET FOR 3 THERMOSTATS
331913	BRACKET
331961	NO-STEAM BRACKET FOR BREAK TAN
331965	BRACKET
350774	BRACKET
450102	CLAMP FE ZN 11-17 H=9
450103	CLAMP FE ZN. 13-20 H=9
450114	CLAMP FE ZN.22-32 H=12,2
450115	ELASTIC CLAMP D.8,3/7,8
450134	ELASTIC HOSE CLIP D.9,3/8,8
450315	KNOB F. THERMOSTAT 90°
460503	SEALING WASHER 38X27X2(3/4)
620209	INLET WATER FILTER
620788	RINSE AID INJECTOR H21428
630969	COIL S4216 220/50HZ
631208	CONDENSER 5MF.450V

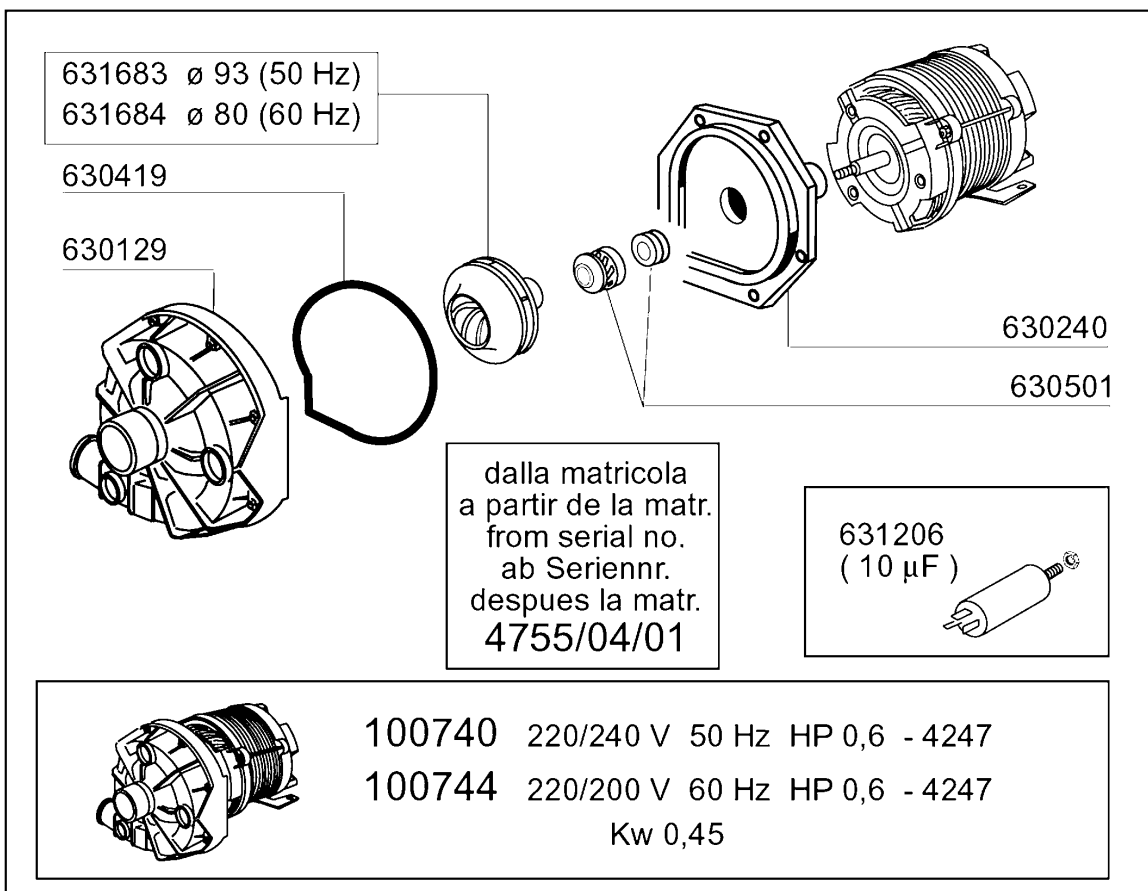
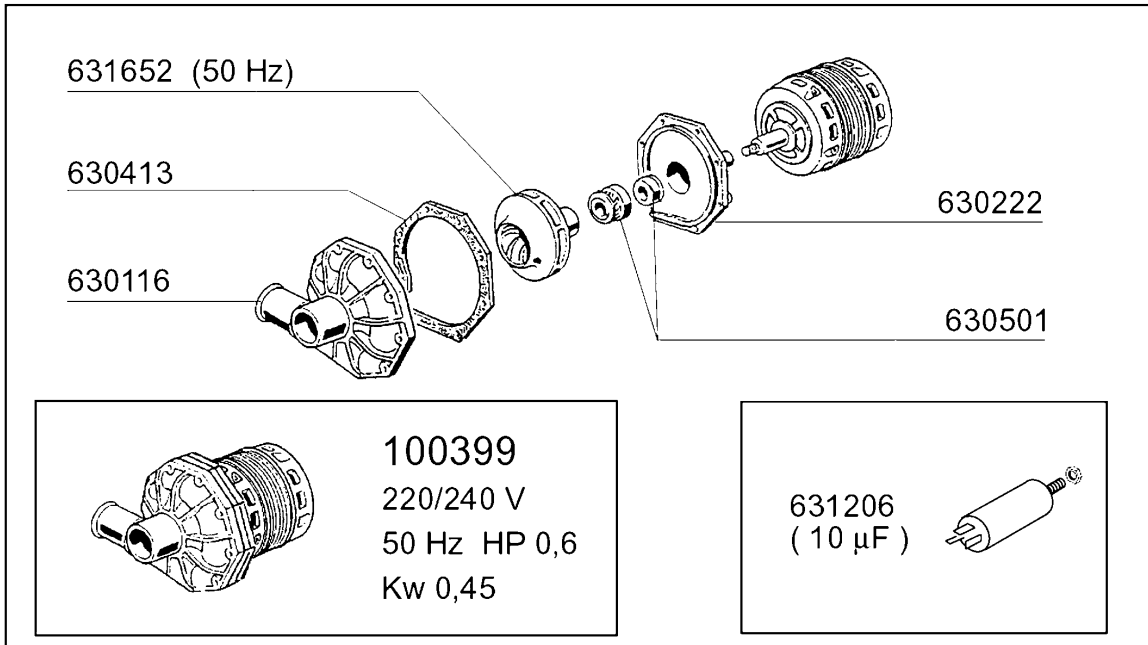

7 - Wash pump

CODE	DESCRIPTION
100399	PUMP HP0,6 220-50HZ (100740)
100740	PUMP 0,6HP 220/240V 4247
100744	PUMP HP 0,6 200-220-60HZ
630116	-NO MORE AVAILABLE
630129	VOLUTE PUMP 0,5HP 2247
630222	COVER PUMP IB HP 0,4
630240	PUMP FLANGE 0,6HP-4247 FIR
630413	-NO MORE AVAILABLE
630419	PUMP GASKET 2247 0,5HP
630501	SEAL FOR PUMP HP 2-3-3,2
631206	CONDENSER 10MF. 450V 85C
631652	-NO MORE AVAILABLE
631683	PUMP IMPELLER 50HZ FIR 4247
631684	IMPELLER FOR PUMP 60 HZ

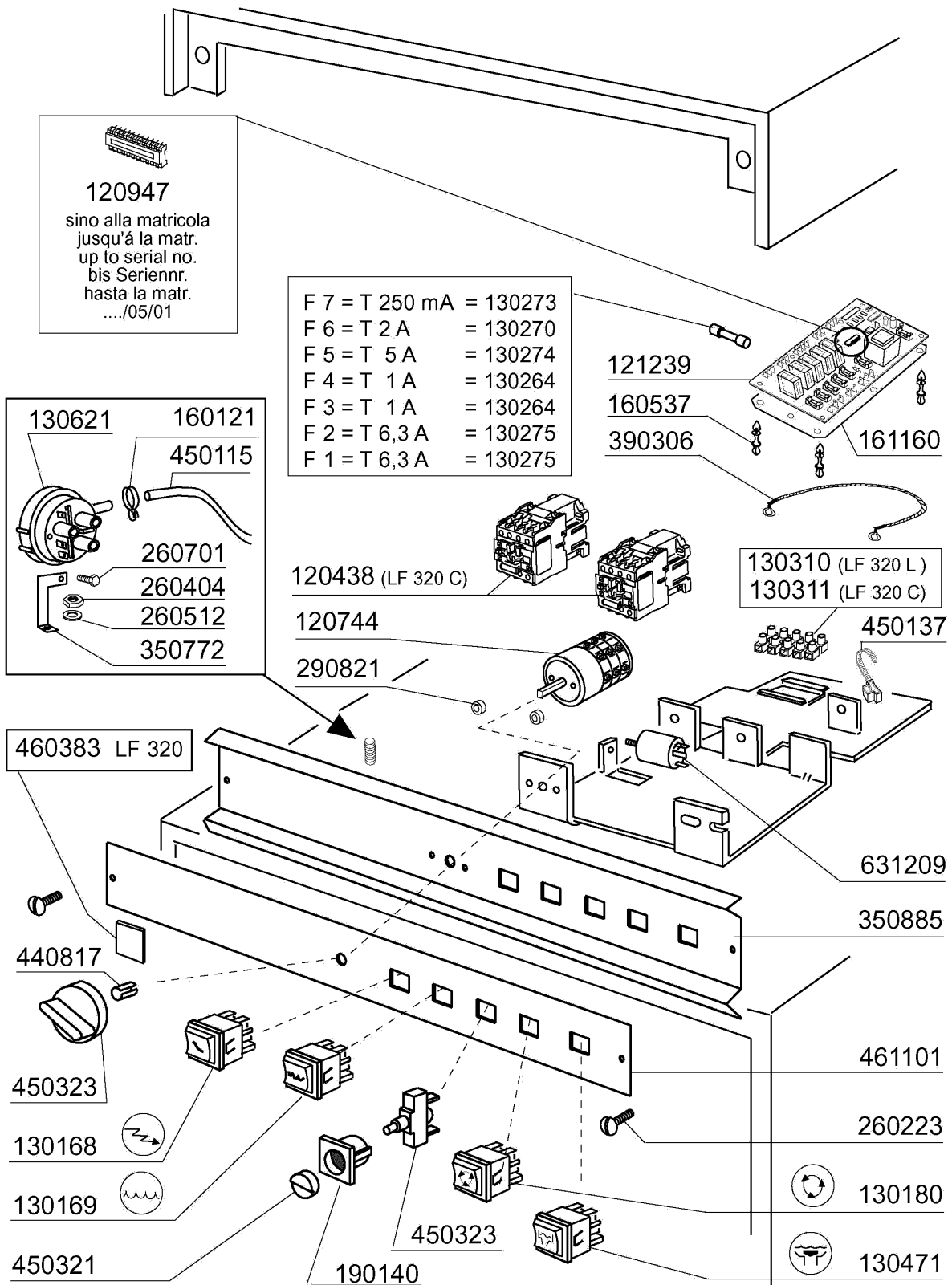

07 - 2001 | S. A. G.

8 - Control box

CODE	DESCRIPTION
120438	CONTACTOR 12A 220V 50HZ
120744	SWITCH QUADRIPOLE.16A 380V
120947	EPROM UNICOM BT
121239	ELECTR.TIMER UNICOM FOR BREAK
130168	LAMP MACHINE ON - LAV-LINE
130169	LAMP MACHINE READY (LAV-LINE)
130180	GREEN LIGHT 24V:WORKING MACHIN
130264	FUSE 5X20 1A
130270	FUSE 5X20 2A
130273	FUSE 5X20 250MA GLAS
130274	FUSE 5X20 5A GLAS
130275	FUSE 5X20 6,3A GLAS
130310	TERMINAL BLOCK 3 POSITIONS
130311	TERMINAL BLOCK
130471	DRAIN PUMP BUTTON
130621	PRESSURE SWITCH FOR BC HR 45/2
160121	HOSE EPDM D. 5 X 9
160537	ELECTRONIC CARD SPACER
161160	PROTECTION ELECT.CARD C/F
190140	BUTTON HOLDER BR-BC-FC
260223	M5X12 MSH/HD SCREW SPECIAL S/S
260404	STAINLESS STEEL NUTS D6 UNI 55
260512	ST/ST GROWER WASHER D6
260701	SCREW 3,5X9,5
290821	DISTANCE PIECE FOR SWITCH
350772	BRACKET
350885	PANEL SUPPORT "LF"
390306	CABLE
440817	SNAP RING LSCB/1853/17/00
450115	ELASTIC CLAMP D.8,3/7,8
450137	COLLAR CONNECTION WITH BASE 31
450321	GREY COVER FOR PUSH BUTTON BR-
450323	KNOB FOR BC-BR-C95-C155
460383	NAME
461101	PLATE LF LAV-LINE
631209	ANTI-NOISE FILTER

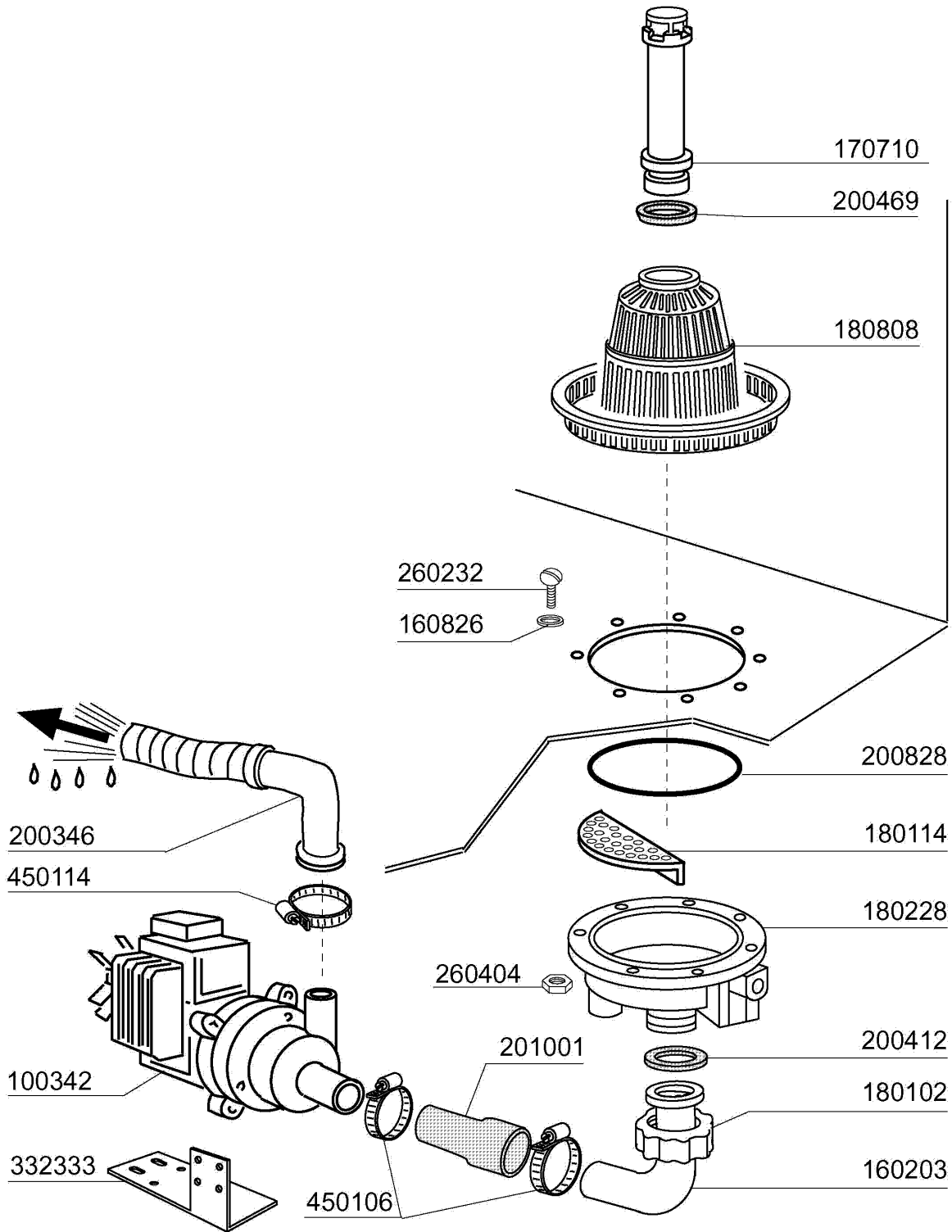

9 - Drain pump

CODE	DESCRIPTION
100342	DRAIN PUMP 100 W 220V
160203	ELBOW 1"1/2 N-S-F-C /DRAIN
160826	GASKET 14X6,2X2 B41-F2
170710	OVERFLOW PIPE X F WITH DRAIN P
180102	DRAIN PIPE NUT 1"1/2 F45-55
180114	KNOB
180228	TANK SUCTION BASIN WITHOU.PRES
180808	STRAINER F2-45-55-80
200346	DRAIN HOSE GLASSWASHER
200412	GASKET DRAIN 11/2" 45X33X3
200469	STAND PIPE O RING 45X35,5X7
200828	O-RING 183,75X190,81X3,53
201001	HOSE FOR DRAIN PUMP LF
260232	STAINL.ST TB SCREW 6X25 B15-6-
260404	STAINLESS STEEL NUTS D6 UNI 55
332333	BRACKET FOR DRAIN PUMP
450106	CLAMP FE ZN 32-44 H=12,2
450114	CLAMP FE ZN.22-32 H=12,2

10 - Rinse aid injector

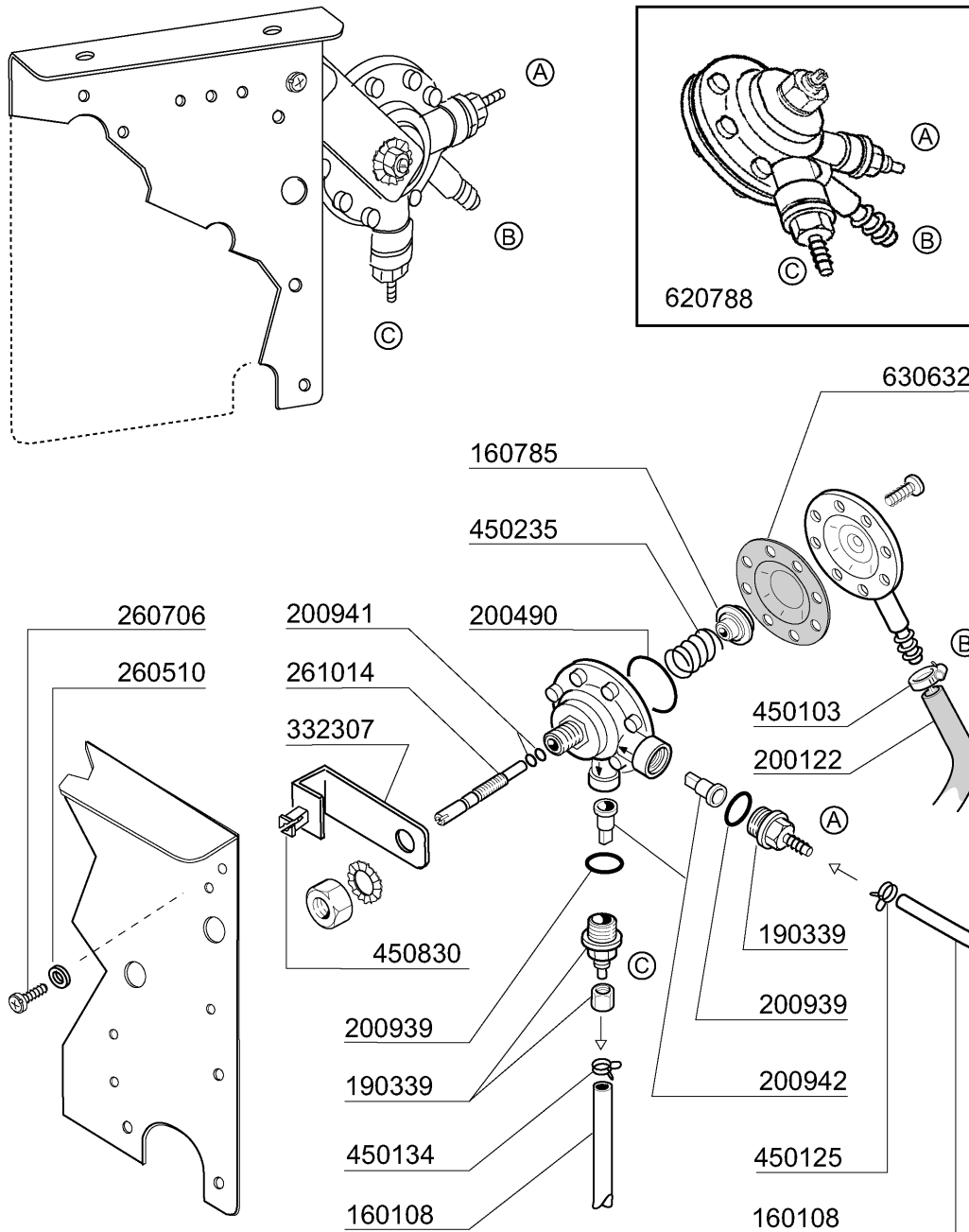

07/2008 M.SA

10 - Rinse aid injector

CODE	DESCRIPTION
160108	INJECT.INLET HOSE D.8X5
160785	GUIDE FOR SPRING RINSE AID INJ
190339	RINSE AID INJECTOR CONNECTION
200122	HOSE 11X19
200490	PROTECTION GASKET MOD.ADV.
200939	OR GASKET
200941	OR GASKET
200942	VALVE RINSE INJECTOR HVD
260510	GROWER WASHER D.4
260706	SCREW 3,9X13 S/S
261014	SCREW
332307	BRACKET
450103	CLAMP FE ZN. 13-20 H=9
450125	ELASTIC CLAMP D. 10,4X9,8
450134	ELASTIC HOSE CLIP D.9,3/8,8
450235	SPRING RINSE AID INJECTOR
450830	SCREW
620788	RINSE AID INJECTOR H21428
630632	DIAPHRAGM RINSE INJECTOR HVD

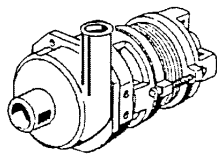

100747 (220/240 V 50 Hz)
Kw 0,073

630416

631640 (50 Hz)

630131

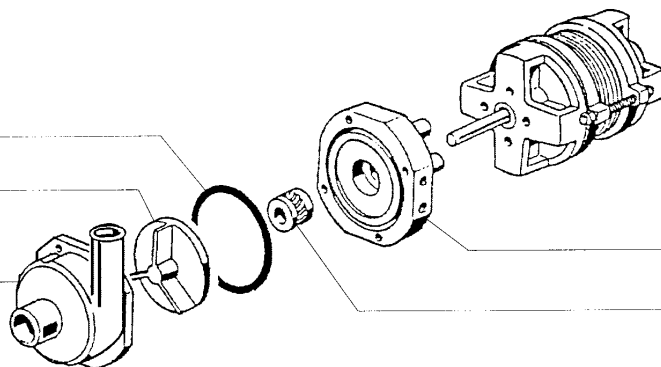

630242

630514

11 - Rinse booster pump

CODE	DESCRIPTION
100747	PUMP KW 0,073 220/240-50 4208
630131	VOLUTE PUMP FIR T.4208
630242	BACKPLATE FIR T.4208
630416	OR FOR VOLUTE 0,12/0,3
630514	PUMP SEAL FIR4208
631640	IMPELLER HP0,20/2212-8/5HZ

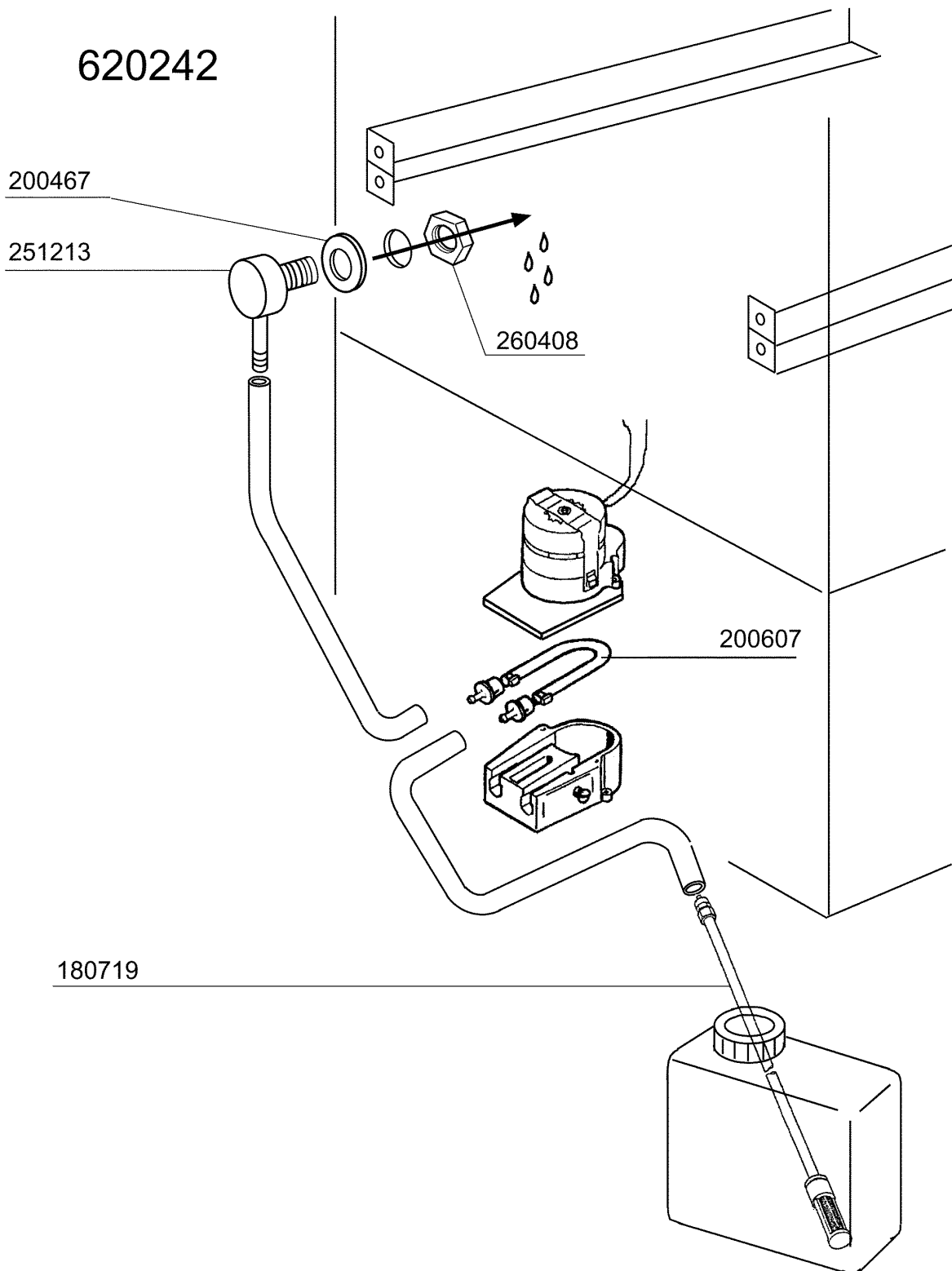

12 - Detergent dispenser

CODE	DESCRIPTION
180719	DETERGENT DISPENSER SUCTION HO
200467	DUTRAL GASKET F. AIR TRAP
200607	DETERGENT DISPENSER HOSE
251213	INJECTIOR S/S FOR DETERGENT IN
260408	S/S NUTS D.12
620242	DETERGENT INJECTOR (KIT)

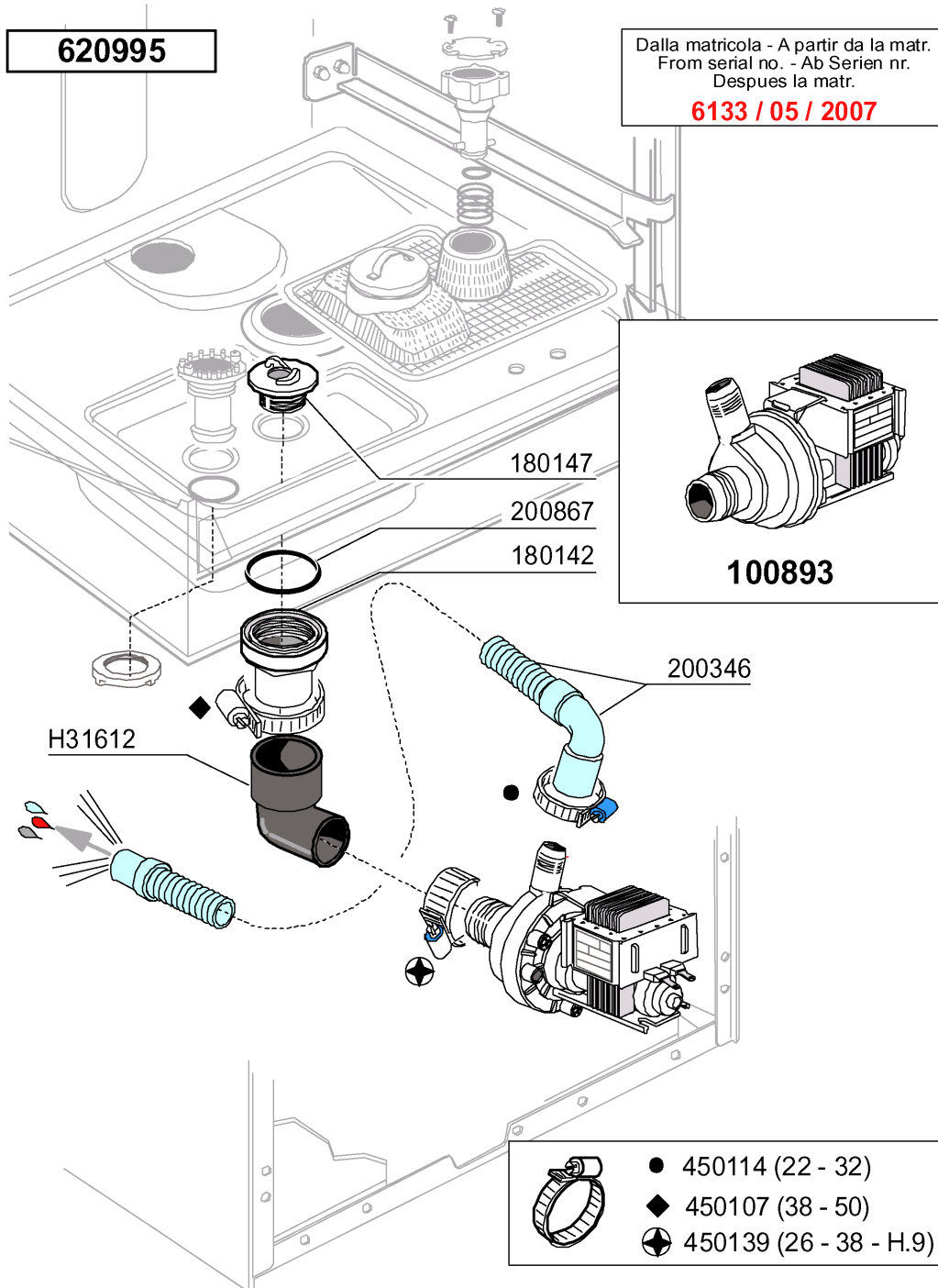

13 - Drain pump

CODE	DESCRIPTION
100893	DRAIN PUMP 30W 230/50
180142	CONNECTOR FOR DRAIN PUMP
180147	NUT
200346	DRAIN HOSE GLASSWASHER
200867	GASKET
450107	CLAMP FE ZN 38-50 H=12,2
450114	CLAMP FE ZN.22-32 H=12,2
450139	CLAMP 26-38 H=9
620995	DRAIN PUMP KIT LF MODELS 2007
H31612	HOSE FOR DRAIN PUMP